

C35-10 – C50

⇒ 3.5 – 5.0 m³/min

Product range DLT 0408

The highly successful CompAir range C35-10 – C50 is driven by very quiet-running, water-cooled Yanmar 4TNV88BKCP 4-cylinder diesel engines. The compressor is particularly suitable for applications in cities and built-up areas, where stringent restrictions are set on noise emissions. The light construction of under 750 kg (C38 and C42) makes the compressor suitable for many different applications and is therefore ideal for use by hire companies. These compact and lightweight compressors are available with various chassis and also with the option of integrated generator or aftercooler or both.

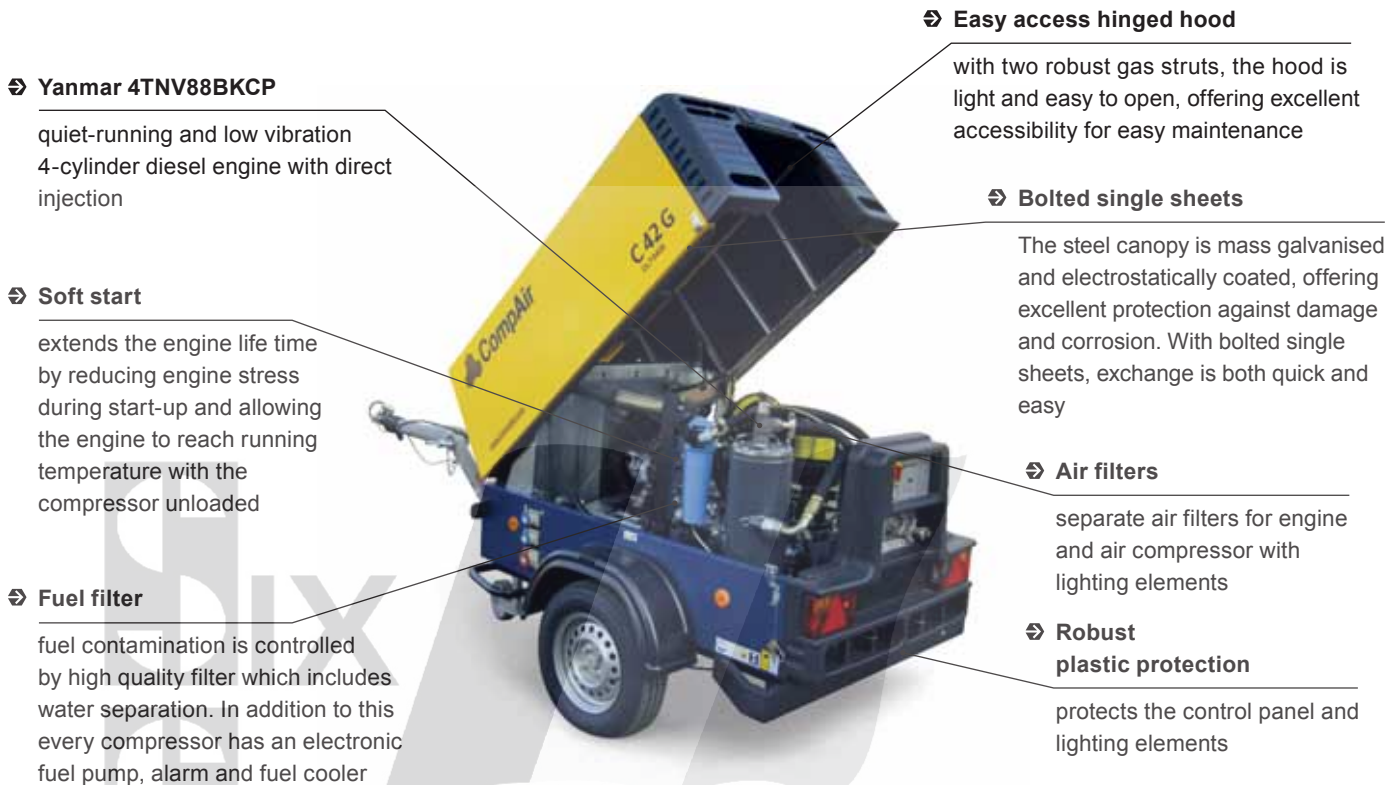

- ⇒ **Progressive volume flow regulation**
engine speed and air intake regulation are automatically adapted to compressed air requirement
- ⇒ **Air end with spin-on oil filter cartridge**
for quick and easy maintenance
- ⇒ **Transparent plastic fuel tank**
allows direct visual level indication and quick contamination checks
- ⇒ **Central lifting eye**
for easy handling by crane
- ⇒ **Operational reliability**
designed for – 10 to + 50° C ambient temperature
- ⇒ **Compressor oil temperature regulating valve**
ensures safe operation of compressor at low ambient temperatures or extreme partial load. Standard!
- ⇒ **Internal main switch** avoids unauthorised operation



Portable-Control 2

- ⇒ **Fully protected digital display** with tamper proof hour counter
- ⇒ **Automatic protection in case of malfunction:**
 - Compressor temperature too high
 - Engine oil pressure too low
 - Engine temperature too high
 - Rotational speed too low
 - Battery voltage too low
 - Fuel level too low
 - Cooling water too low
- ⇒ **Indication lamps** for
 - Preheat
 - Operation
 - Automatic emergency stop after malfunction
- ⇒ **Start by rotary switch** to avoid loss of time caused by lost ignition key

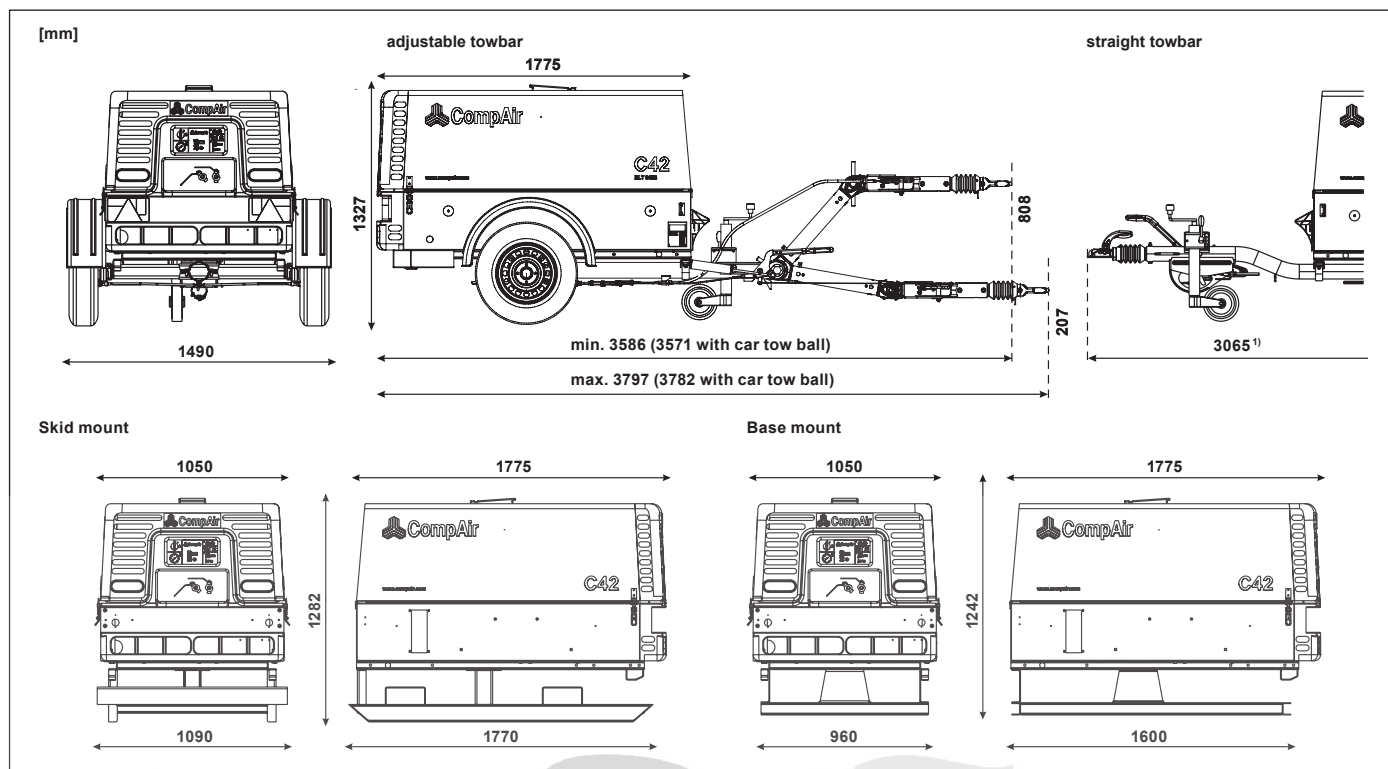

AirPlus options on fold out page →

Product range		DLT 0408				
Type		C35-10	C38	C42	C50	
Operational data						
Volume flow ¹⁾ (Optional 9 or 15 kVA Generator)	m ³ /min	3.5	3.8	4.2	5.0	
Operating pressure	bar	10	7	7	7	
Compressed air outlet		2 x 3/4"				
Engine						
Yanmar 4TNV88BKCP						
Installed engine power	kW	35.0	35.0	35.0	35.0	
Engine off load speed	1/min	1600	1600	1600	1600	
Engine full load speed	1/min	2800	2800	2800	2800	
Fuel tank capacity	l	60	60	60	60	
Operating weight²⁾						
Portable compressor	adjustable towbar braked	kg	810	810	810	866
	adjustable towbar unbraked	kg	745	745	745	–
	straight towbar braked	kg	775	775	775	835
	straight towbar unbraked	kg	740	740	740	800
Base mount	kg	685	685	685	780	
Skid mount	kg	740	740	740	800	
Dimensions						
Length	adjustable towbar braked	mm	3586 - 3797	3586 - 3797	3586 - 3797	3586 - 3797
	straight towbar braked	mm	3065	3065	3065	3065
Width	mm	1490	1490	1490	1490	
Height (adjustable towbar, braked)	mm	1327	1327	1327	1327	
Length of canopy	mm	1775	1775	1775	1775	
Sound level						
Power sound level ³⁾	dB(A) LWA	98	98	98	98	
Pressure sound level ⁴⁾	dB(A) LPA	69	69	69	69	

¹⁾ Acc. to ISO 1217 Ed. 4 2009 Annex D

²⁾ Operating weight without options

³⁾ Legal limiting values of EC directive acc. to 2000/14/EC

⁴⁾ Noise level acc. to PNEUROP PN8NTC2.2 at 7 m